

# Sequential mechanical BIOSAFE basin mixer

Ref. 2665T1

Single hole sequential tall mixer H. 160mm L. 160mm

## DESCRIPTION

### Sequential mechanical BIOSAFE basin mixer - Ref. 2665T1

Deck-mounted mechanical tall basin mixer.  
 Sequential mechanical mixer: opens and closes with cold water over a 70° range.  
 Single hole mixer with fixed spout H. 160mm L. 160mm.  
 Tall mixer with BIOSAFE hygienic outlet suitable for BIOFIL terminal filters.  
 Ø 35mm sequential ceramic cartridge with pre-set maximum temperature limiter.  
 Spout with tube with smooth interior has nowhere for bacteria to develop and a very low water volume.  
 The water velocity inside this tube reduces biofilm development considerably.  
 Thermal shocks are easy to undertake without removing the control lever or shutting off the cold water supply.  
 Body with very low volume of water (fewer niches where bacteria can develop).  
 Flow rate regulated at 5lpm.  
 No manual contact thanks to Hygiene control lever L. 200mm. F3/8" rotating PEX flexibles.  
 No risk of cross flow between the hot and cold water.  
 No non-return valves.  
 Fixings reinforced via 2 stainless steel rods.  
 Mechanical mixer is ideal for healthcare facilities, retirement and care homes, hospitals and clinics.  
 Sequential mixer is suitable for people with reduced mobility.  
 Mixer with 30-year warranty.





## TECHNICAL CHARACTERISTICS

### Sequential mechanical BIOSAFE basin mixer - Ref. 2665T1

Supply	3/8"
Technology	Sequential mechanical mixer
Drop height	160mm
Spout length	160mm
Flow rate	5 lpm
Temperature limiter	Yes
Finish	Chrome-plated brass
Norms	 ACS



## ADVANTAGES

-  Sequential: opens/closes with cold water
-  Thermal shock without removing the control lever
-  Maximum hygiene: controls biofilm
-  No manual contact: Hygiene control lever

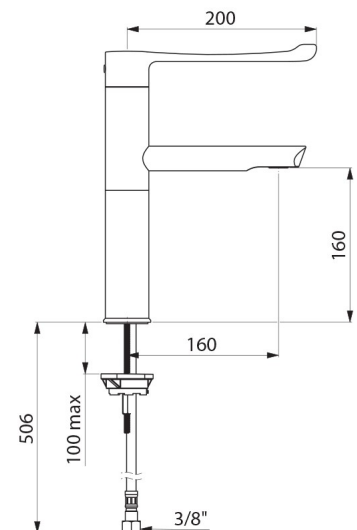

---

Warranty

